

DMX2PWM Dimmer 4CH Instructions



Highlights

- 4 PWM output channels
- Adjustable PWM output resolution ratio (8 or 16 bit) for smooth dimming (via RDM or buttons & display)
- Configurable PWM frequency (0.5 ... 35kHz) for flicker full free dimming (via RDM or buttons & display)
- Settable output dimming curve gamma value (0.1 ... 9.9) for true color matching (via RDM or buttons & display)
- Wide input/output voltage range: 12 ... 36 V DC
- 13 personalities to determine how many DMX channels control the PWM output
- Integrated standalone mode with Controller functionality for smaller projects
- RDM functionality
- Rich pre-configured scenes
- Built-In display with buttons for easy and user friendly configuration and on-site testing
- Integrated protection against surge on DMX interface

Delivery Content

Identcode

- e:cue DMX2PWM Dimmer 4CH AM467260055
- Welcome note
- Instructions (English)

Product Specifications

Dimensions (W x H x D)	170 x 53.4 x 28 mm / 6.69 x 2.09 x 1.1 in
Weight	170 g
Power input	12 ... 36 V DC (4-pin terminal)
Max. input current at "power input"	20.5 A
Operating temperature	-20 ... 50 °C / -4 ... 122 °F
Storage temperature	-40 ... 85 °C / -40 ... 185 °F
Operation / storage humidity	5 ... 95% RH, non-condensing
Mounting	with key hole on any stable vertical surface
Protection class	IP20
Housing	PC
Certificates	CE, UKCA, RoHS, FCC, UR, TÜV Süd

Interfaces

Input	1 x DMX512 / RDM (3-pin terminal), isolated, surge protection
Outputs	1 x DMX512 / RDM (3-pin terminal) for chaining multiple devices (max. 256), isolated, surge protection 4 x PWM channel (5-pin terminal) for constant voltage + connector: identical to input voltage - connector: low side PWM switch
Max. output current	5 A per channel
Output power	60 ... 180 W per channel
PWM frequency	0.5 ... 35 kHz
PWM output resolution	8 bit or 16 bit
Output dimming curve gamma	0.1 ... 9.9 ga

Always select the power supply output voltage accordingly to your LED fixture input voltage!

12 V PSU for 12 V LED
24 V PSU for 24 V LED
36 V PSU for 36 V LED

Terminals

Connection type	Spring terminal connectors
Wire size solid core, stranded wire with end ferrule	0.5 ... 2.5 mm ² (AWG20 ... AWG13)
Stripping length	6 ...7 mm / 0.24 ... 0.28 in
Tightening / release of wire	Push mechanism



Dimensions

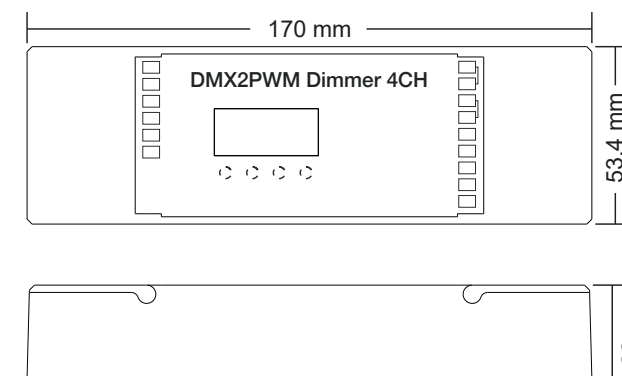

Safety & Warnings

- ⚠ Do not install with power applied to device.
- Do not expose the device to moisture.
- Read the instructions prior to installation.



For further product information and downloads see www.ecue.com.

Installation

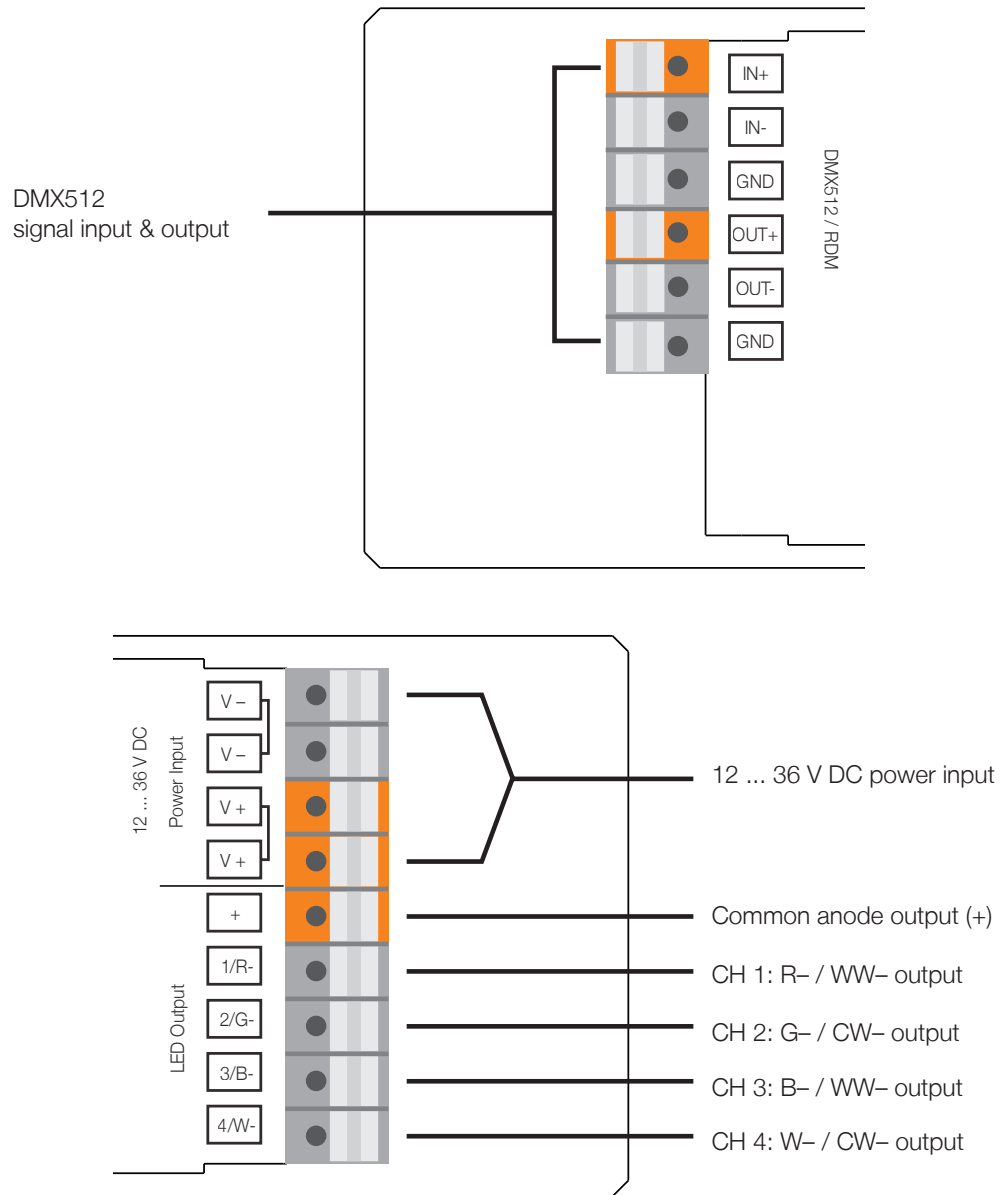

Wiring Diagram

⚠ Install a 120 Ω, 0.5 W resistor between Out + and Out - ports on the last device of the DMX run.

- System with an external DMX controller
 - Total load of each LED receiver is not over 10 A

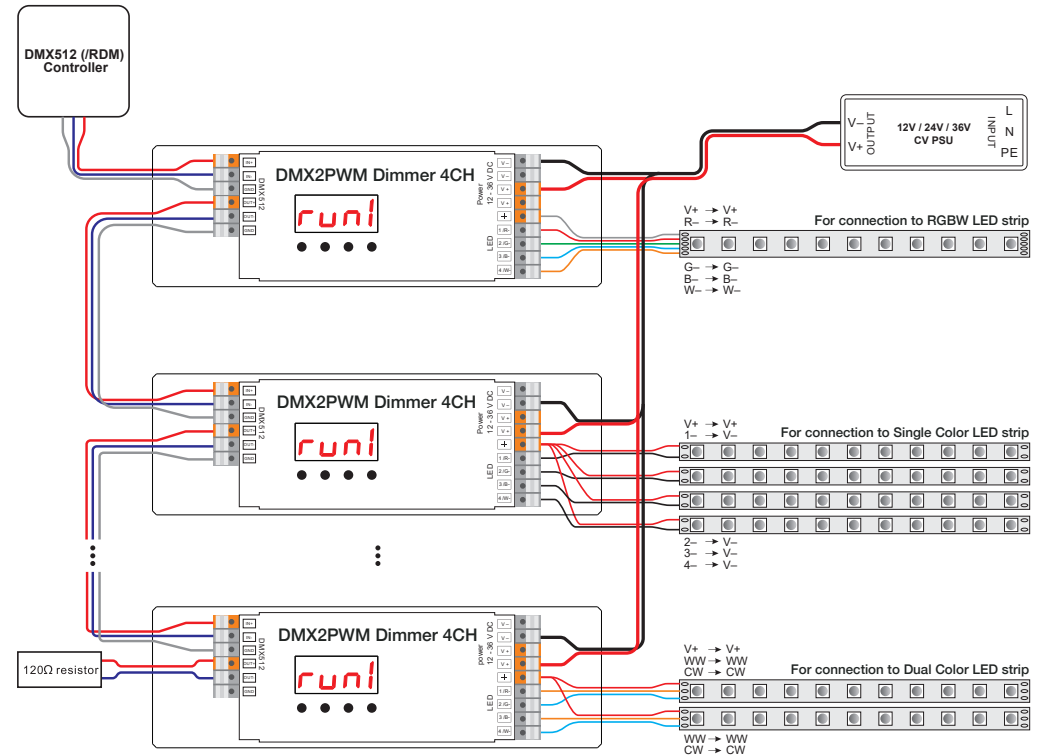

1.2) Total load of each LED receiver is over 10 A

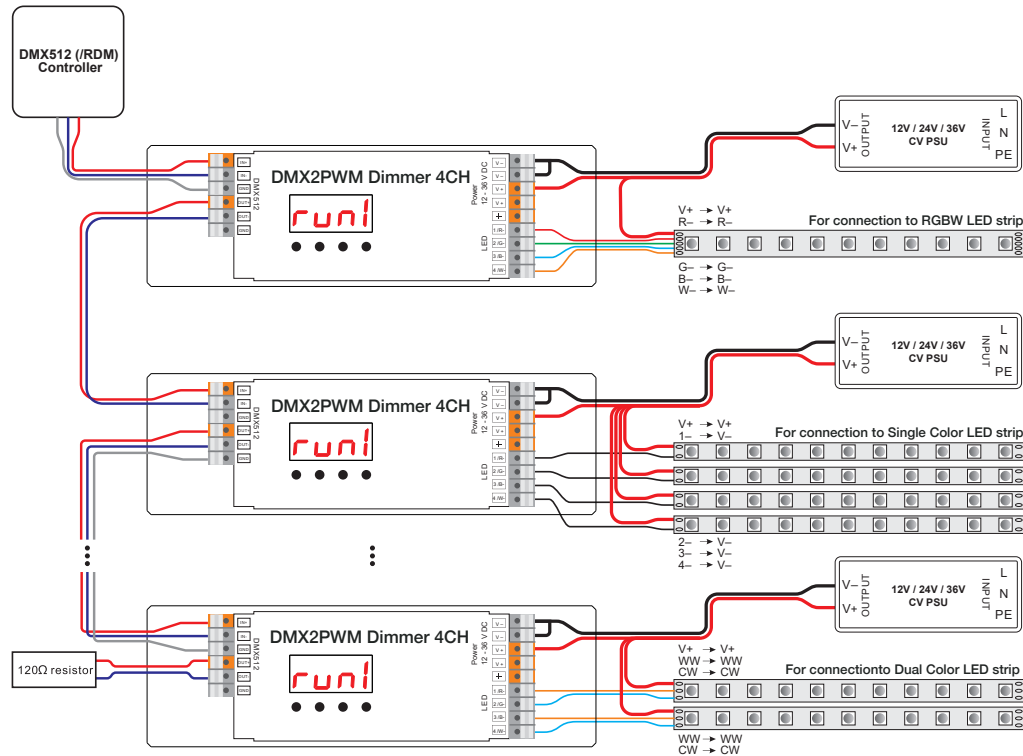

2. Standalone system

2.1) Total load of each LED receiver is not over 10 A

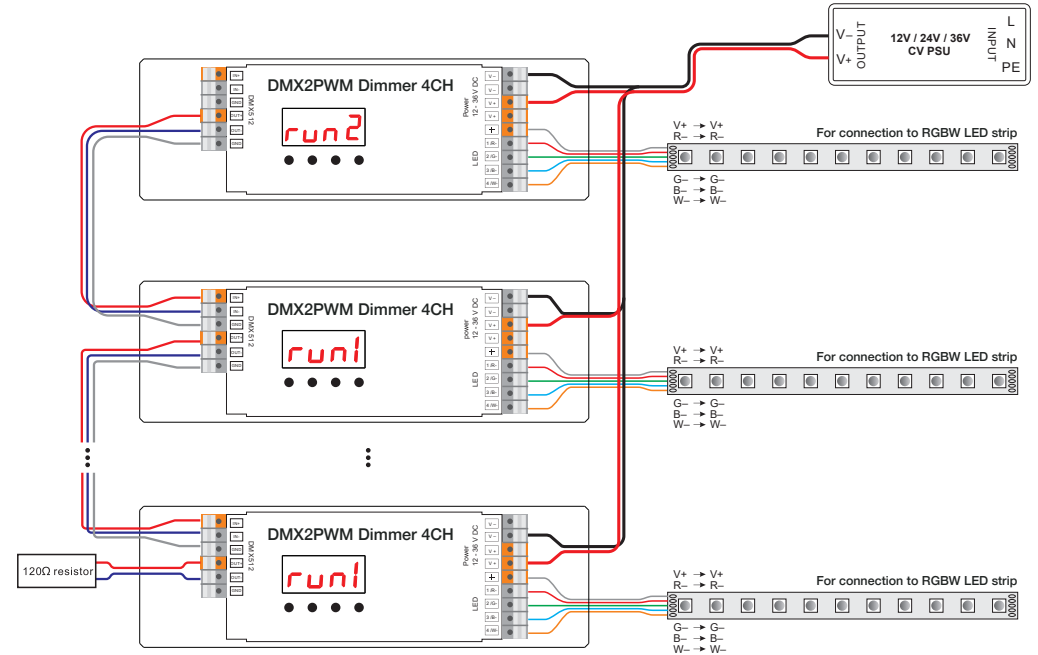

2.2) Total load of each LED receiver is over 10 A

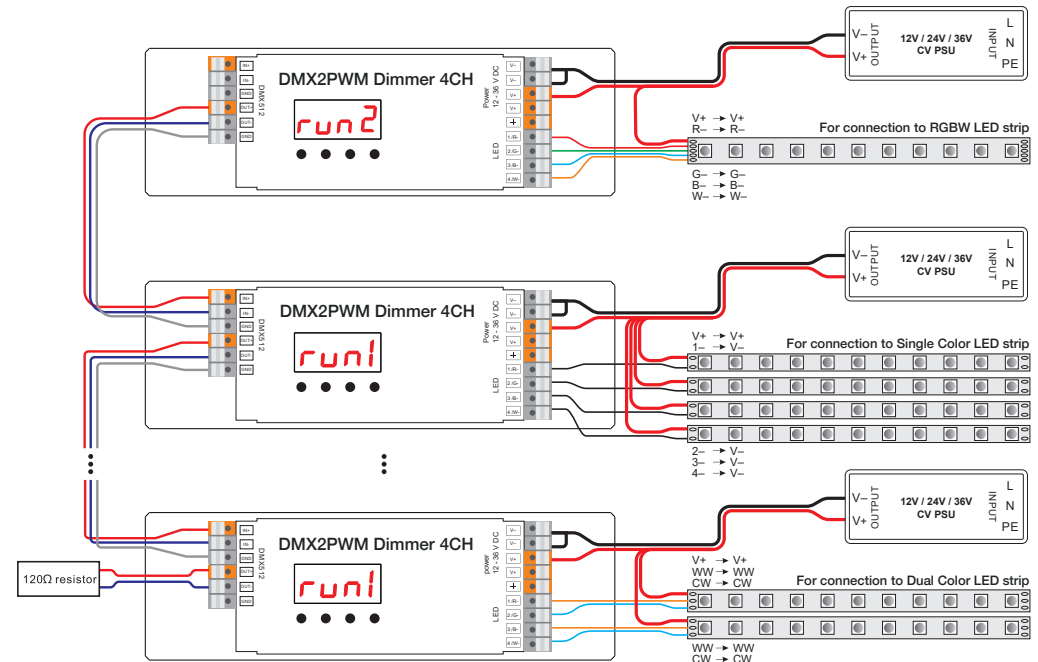

Device Setup

To configure the settings, press the buttons in the following sequence accordingly:

1. **Up / Down** --- select a menu entry
2. **Enter** --- access the menu entry, the display flashes
3. **Up / Down** --- set the value
4. **Back** --- confirm the value and exit the menu entry.



Operating mode setting:

Set the device to Dependent or Controller mode first, before you configure other settings:

run1 = Dependent mode

In a system with an external DMX controller, set all DMX2PWM Dimmer 4CH devices to **run1** mode.

In a standalone system (no external DMX controller), set all dependent DMX2PWM Dimmer 4CH devices to **run1** mode.

run2 = Controller mode (standalone)

In a standalone system, set the controlling DMX2PWM Dimmer 4CH device to **run2** mode.



After setting the mode, a restart of the device is required.

a) run1:

DMX signal indicator **●**: When a DMX signal input is detected, the indicator on the display following the **A** turns red: **A.XXX**. If there is no DMX signal input, the indicator does not turn on and the character **A** flashes.

1. DMX address setting:

Menu **A XXX**. Default setting is 001 (**A001**).

2. DMX personality setting:

Menu **IRo1, ..., Bdo2**. Default setting is **4d.01**.

Set the DMX channel quantity used to control the corresponding PWM output channel quantity:

DMX personality DMX channel	1A.01	2A.02	2b.01	3b.03	3c.01	4b.02
1	all outputs dimming	all outputs dimming	outputs 1 & 3 dimming	outputs 1 & 3 dimming	output 1 dimming	outputs 1 & 3 dimming
2		all outputs fine dimming	outputs 2 & 4 dimming	outputs 2 & 4 dimming	output 2 dimming	outputs 1 & 3 fine dimming
3				all outputs master dimming	outputs 3 & 4 dimming	outputs 2 & 4 dimming
4						outputs 2 & 4 fine dimming
5						
6						
7						
8						

DMX personality DMX channel	4c.03	4d.01	5c.04	5d.03	6c.02	6d.04	8d.02
1	output 1 dimming	output 1 dimming	output 1 dimming	output 1 dimming	output 2 dimming	output 1 dimming	output 1 dimming
2	output 2 dimming	output 2 dimming	output 2 dimming	output 2 dimming	output 1 fine dimming	output 2 dimming	output 1 fine dimming
3	outputs 3 & 4 dimming	output 3 dimming	outputs 3 & 4 dimming	output 3 dimming	output 2 dimming	output 3 dimming	output 2 dimming
4	all outputs master dimming	output 4 dimming	all outputs master dimming	output 4 dimming	output 2 fine dimming	output 4 dimming 4	output 2 fine dimming
5			strobe effects	all outputs master dimming	outputs 3 & 4 dimming	all outputs master dimming	output 3 dimming
6					outputs 3 & 4 fine dimming	strobe effects	output 3 fine dimming
7							output 4 dimming
8							output 4 fine dimming

Data definitions for strobe effects:

{0, 7},//undefined

{8, 65},//slow strobe-->fast strobe

{66, 71},//undefined

{72, 127},//slow push fast close

{128, 133},//undefined

{134, 189},//slow close fast push

{190, 195},//undefined

{196, 250},//random strobe

{251, 255},//undefined

3. Output dimming curve gamma value setting:

Menu **9A** XX. Default setting is ga 1.5 (**gA1.5**).
Select between **0.1** ... **9.9**.

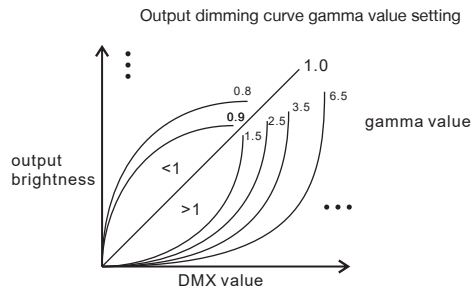

4. Output PWM frequency setting:

Menu **PF** XX. Default setting is 4 kHz (**PF04**).
Select the PWM frequency: **00** = 0.5 kHz, **01** = 1 kHz, **02** = 2 kHz ... 25 = 25 kHz, **35** = 35 kHz.

5. PWM output resolution bit setting:

Menu **bt** XX. Default setting is 16 bit (**bt16**).
Select between **08** = 8 bit and **16** = 16 bit.

6. Startup behavior setting:

Menu **5b**-X. Default setting is "hold last frame" (**5b-0**).
Set the startup behavior of the device. The startup behavior is the state of the device after a restart or when it is offline:

- 0** (via RDM: **0**) - Hold last frame
- 1** (via RDM: **1**) - RGBW = 0%
- 2** (via RDM: **2**) - RGBW = 100%
- 3** (via RDM: **3**) - Channel 4 = 100%, channels 1 and 2 and 3 = 0%
- 4** (via RDM: **4**) - Channel 1 = 100%, channels 2 and 3 and 4 = 0%
- 5** (via RDM: **5**) - Channel 2 = 100%, channels 1 and 3 and 4 = 0%
- 6** (via RDM: **6**) - Channel 3 = 100%, channels 1 and 2 and 4 = 0%
- 7** (via RDM: **7**) - Channels 1 and 2 = 100%, channels 3 and 4 = 0%
- 8** (via RDM: **8**) - Channels 2 and 3 = 100%, channels 1 and 4 = 0%
- 9** (via RDM: **9**) - Channels 1 and 3 = 100%, channels 2 and 4 = 0%
- A** (via RDM: **10**) - Channel 1 = 100%, channel 2 = 45%, channels 3 and 4 = 0%.

b) run2 :

1. PWM brightness setting:

Menu **1-01**. Set the brightness for each output PWM channel.
First **1** means PWM output channel 1. Select between 1 ... 4.
Second **01** means brightness level. Select between **00** - 0% ... **99** - 99% ... **FL** - 100% brightness.

2. RGB effect brightness setting:

Menu **b**-XX. Set the RGB running effect's brightness, in total 1 ... 8 levels of brightness.

3. Effect speed setting:

Menu **5P**-X. Set the effect play speed, in total 1 ... 9 levels of speed.

4. Pre-defined program setting:

Menu **P**-XX. Select a pre-defined RGB color changing program, in total 32 programs (P-XX).

- 00** - RGBW off
- 01** - Static red (output channel 1)
- 02** - Static green (output channel 2)
- 03** - Static blue (output channel 3)
- 04** - Static white (output channel 4)
- 05** - Static yellow (50% red + 50% green)
- 06** - Static orange (75% red + 25% green)
- 07** - Static cyan (50% green + 50% blue)
- 08** - Static purple (50% blue + 50% red)
- 09** - Static white (100% red + 100% green + 100% blue)
- 10** - RGBW 4 channels fade in & fade out as diagram:



- 11** - RGBW 4 channels fade in & fade out as diagram:

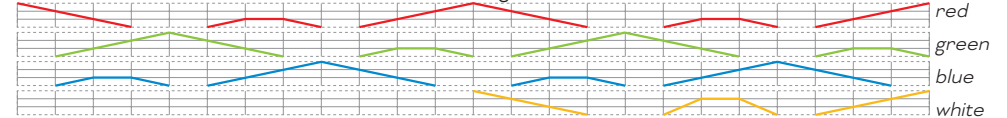

- 12** - RGBW 4 channels fade in & fade out as diagram:



- 13** - RGBW 4 channels jump in & jump out as diagram:

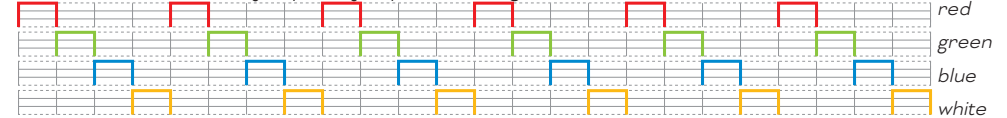

- 14** - RGBW 4 channels fade in & jump out as diagram:



- 15** - RGBW 4 channels jump in & jump out as diagram:



- 16** - RGBW 4 colors strobe
- 17** - RGB mix white (100% red + 100% green + 100% blue) + 4th channel W (100% white) strobe
- 18** - 8 colors fade in & fade out (red, orange, yellow, green, cyan, blue, purple, white (4th channel))
- 19** - 8 colors jump changing (red, orange, yellow, green, cyan, blue, purple, white (4th channel))
- 20** - 8 colors strobe (red, orange, yellow, green, cyan, blue, purple, white (4th channel))

- 21 - Red-white (100% red + 100% green + 100% blue) -W (4th channel) circle gradual changing
- 22 - Green-white (100% red + 100% green + 100% blue) -W (4th channel) circle gradual changing
- 23 - Blue-white (100% red + 100% green + 100% blue) -W (4th channel) circle gradual changing
- 24 - Red-orange-W (4th channel) circle gradual changing
- 25 - Red-purple-W (4th channel) circle gradual changing
- 26 - Green-yellow-W (4th channel) circle gradual changing
- 27 - Green-cyan-W (4th channel) circle gradual changing
- 28 - Blue-purple-W (4th channel) circle gradual changing
- 29 - Blue-cyan-W (4th channel) circle gradual changing
- 30 - Red-yellow-green-W (4th channel) circle gradual changing
- 31 - Red-purple-blue-W (4th channel) circle gradual changing
- 32 - Green-cyan-blue-W (4th channel) circle gradual changing

Restore Factory Defaults

To restore the default settings of the device, press and hold down **Back** + **Enter** together at the same time until the display turns off. Then release the buttons, the system resets. The digital display turns on again, all settings are restored to the default settings.

Setting	Default Value
Operation mode	run1
DMX address	A001
DMX personality	4d.01
Output dimming curve gamma value	gA1.5
Output PWM frequency	PF04
PWM output resolution bit	bt16
Startup behavior	Sb-0

RDM Discovery Indication

When using RDM to discover the device, the digital display will flash and the connected lights will also flash at the same frequency to indicate. Once the display stops flashing, the connected light also stops flashing.

Supported RDM PIDs:

DISC_UNIQUE_BRANCH	SLOT_DESCRIPTION
DISC_MUTE	OUT_RESPONSE_TIME
DISC_UN_MUTE	OUT_RESPONSE_TIME_DESCRIPTION
DEVICE_INFO	STARTUP_BEHAVIOR
DMX_START_ADDRESS	MANUFACTURER_LABEL
DMX_FOOTPRINT	MODULATION_FREQUENCY
IDENTIFY_DEVICE	MODULATION_FREQUENCY_DESCRIPTION
SOFTWARE_VERSION_LABEL	PWM_RESOLUTION
DMX_PERSONALITY	CURVE
DMX_PERSONALITY_DESCRIPTION	CURVE_DESCRIPTION
SLOT_INFO	SUPPORTED_PARAMETERS