



Allegro Dot M CW Allegro Dot L CW

Allegro Dot CW is the next generation of intelligent media dot family. It is an extra bright Cold White clear or diffused dot. The dots can provide advanced features and flexibility for lighting design and project execution. Customizable pitch containing up to 38 dots max in Dot M and 22 dots max in Dot L.

Product Specifications



Model	Allegro Dot M CW Direct View	Allegro Dot M CW Diffused View	Allegro Dot L CW Direct View	Allegro Dot L CW Diffused View
Light Source	6 White LEDs per dot		8 White LEDs per dot	
Beam Angle	110°	150°	110°	150°
Luminous Flux¹	185 lm	167 lm	298 lm	260 lm
Efficacy¹	96 lm/W	87 lm/W	94 lm/W	82 lm/W
Cover Lens	Clear (PC)	Diffuser dome (PC)	Clear (PC)	Diffuser dome (PC)
LED Pitch	100mm to 4000mm; Standard: 150mm			
Housing	Die cast aluminum with PC cover			
Adjustment Options	Flexible cable			
Dimensions (Ø x L x H)	Ø68 x 60 x 17mm Ø2.7" x 2.4" x 0.7"	Ø68 x 60 x 39mm Ø2.7" x 2.4" x 1.5"	Ø68 x 60 x 17mm Ø2.7" x 2.4" x 0.7"	Ø68 x 60 x 39mm Ø2.7" x 2.4" x 1.5"
Weight	80g	90g	80g	90g
Regulatory Listing & Safety Approval	cETLus, 3G ANSI C136.31			
Operating Temperature	-30°C to +50°C/-22°F to +122°F			
Storage Temperature	-40°C to +70°C/-40°F to +158°F			
Environment	Outdoor (IP66, IP67), suitable for coastal environments			
Humidity	0 to 90% non-condensing			

Electrical Specifications

Operating Voltage	30V DC	
Power Consumption¹	2W	3W

System Specifications

Control	DMX512/e:pix/RDM/e:net
Power Supply	LED ENG 100W 30V IP67 AL DO (Class 2)
Addressing Options	Auto-Addressing

1. Measurement per dot.

LED CHARACTERISTICS Because LEDs are semiconductor devices, their performances are subject to inherent variability commonly found in semiconductor industry. To improve consistency in performance across the same product, LED manufacturers "sort" LEDs into bins according to different preset parameters, such as forward driving voltage, illumination, etc. Whereas binning is a sorting function, it is not a correction process. Inherent variability in the manufacturing process results always in different binning distributions according to different production lots. Traxon uses automatically binned LEDs on its products, thereby minimizing output variations within the model range.

As with all electronic devices, LED output degrades over time – a term called lumen depreciation. This also explains why it is nearly impossible to expect photometric performances of two LED products with different service life spans to be the same. The rate of LED degrade is a complicate function of many factors such as operating efficiency, duration of continuous operation, and more significantly, environmental conditions (ambient temperature for example). If allowed working under optimal operating temperature range and with good ventilation, LED devices enjoy long service lives over conventional light sources. When using/installing LED devices, care should be taken to ensure that the devices will operate within the operating conditions specified in respective product literature.

www.traxontechnologies.com

©2019 TRAXON TECHNOLOGIES - AN OSRAM BUSINESS. ALL RIGHTS RESERVED. TRAXON™, TX CONNECT®, ARE TRADEMARKS OF TRAXON TECHNOLOGIES. U.S. PATENTS, E.U. PATENTS, JAPAN PATENTS, OTHER PATENTS PENDING. SPECIFICATIONS ARE SUBJECT TO CHANGE WITHOUT NOTICE.

Allegro Dot M CW (Clear Cover) Allegro Dot L CW (Clear Cover)

Photometrics

Source Specifications

Source	6 LEDs packaged in White (One AL Dot M)	8 LEDs packaged in White (One AL Dot L)
Optics	110° (Clear cover)	

Candela Distribution

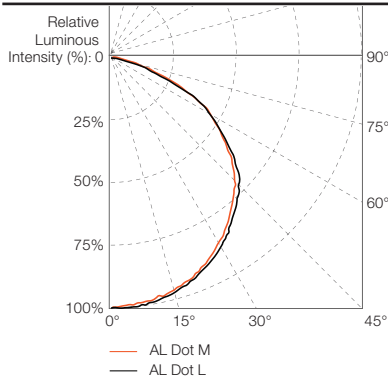

Light Output

	Color	Luminous Flux (lm)	Candela Distribution at 100%	Efficacy (lm/W)
AL Dot M	White	185.19	67.07	96.45
AL Dot L	White	297.7	104.85	93.91

Illuminance at a Distance

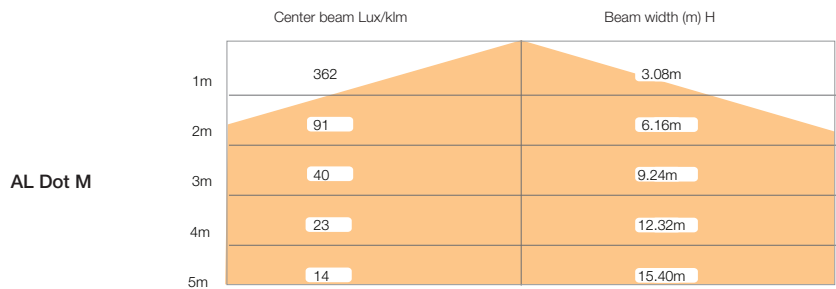

● Horiz. Spread: 114.0°
For feet multiply by 3.28

For fc divide by 10.7
IES and LDT files are available for download from the Traxon website.

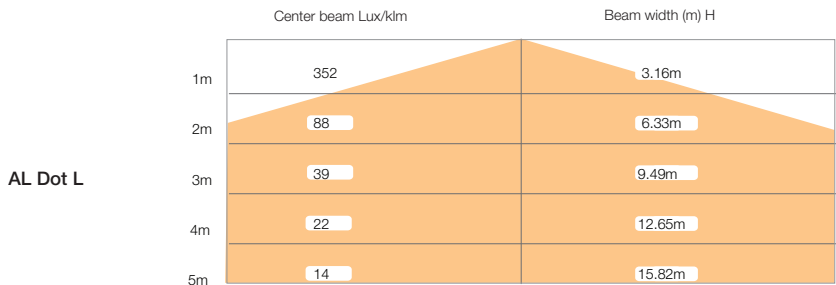

● Horiz. Spread: 115.4°
For feet multiply by 3.28

For fc divide by 10.7
IES and LDT files are available for download from the Traxon website.

Allegro Dot M CW (Diffuser Dome Cover) Allegro Dot L CW (Diffuser Dome Cover)

Photometrics

Source Specifications

Source	6 LEDs packaged in White (One AL Dot M)	8 LEDs packaged in White (One AL Dot L)
Optics	150° (Diffuser Dome cover)	

Candela Distribution

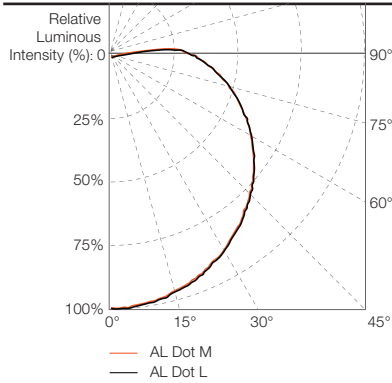

Light Output

	Color	Luminous Flux (lm)	Candela Distribution at 100%	Efficacy (lm/W)
AL Dot M	White	166.67	37.33	86.81
AL Dot L	White	260.06	58.24	82.04

Illuminance at a Distance

	Center beam Lux/klm	Beam width (m) H
AL Dot M	224	7.46m
	56	14.93m
	25	22.39m
	14	29.86m
	9	37.32m

● Horiz.Spread: 150.0°
For feet multiply by 3.28

For fc divide by 10.7
IES and LDT files are available for download from the Traxon website.

	Center beam Lux/klm	Beam width (m) H
AL Dot L	224	7.46m
	56	14.93m
	25	22.39m
	14	29.86m
	9	37.23m

● Horiz.Spread: 150.0°
For feet multiply by 3.28

For fc divide by 10.7
IES and LDT files are available for download from the Traxon website.

Dot M/ L Direct View

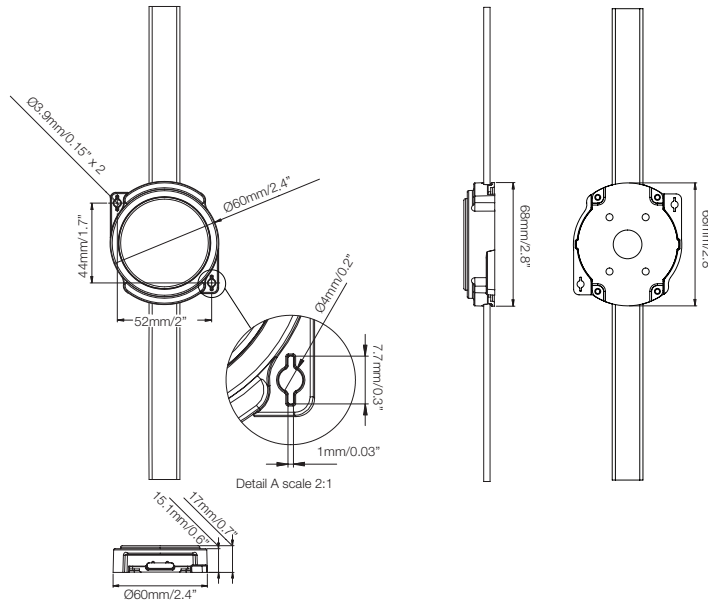

Dot M/ L Diffused View

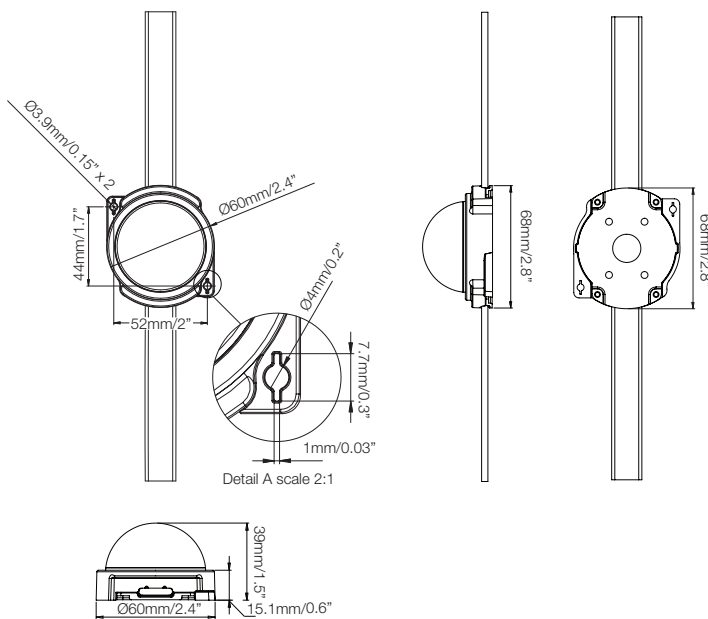

Pixel Distributor with Power Supply (Outdoor 100W)

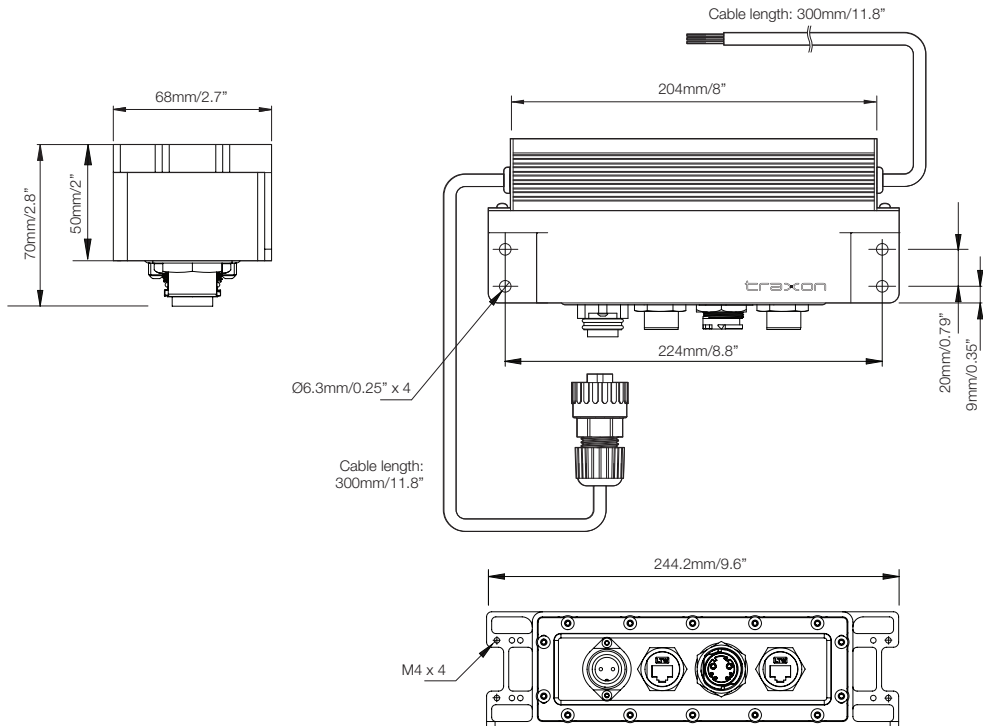

Dot M/ L Smart Junction

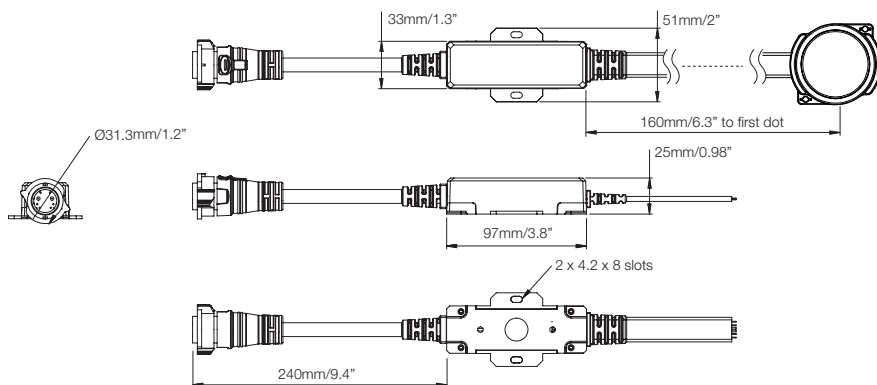

Dot M/ L

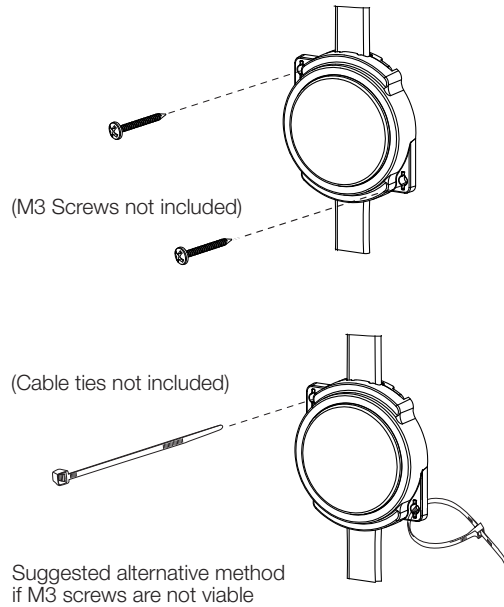

Pixel Distributor

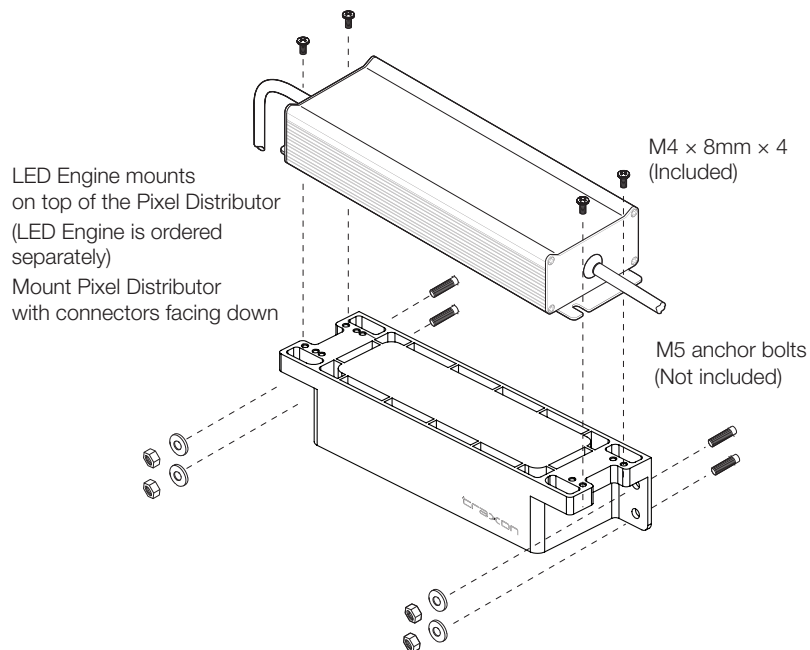

System Diagram—e:net connection

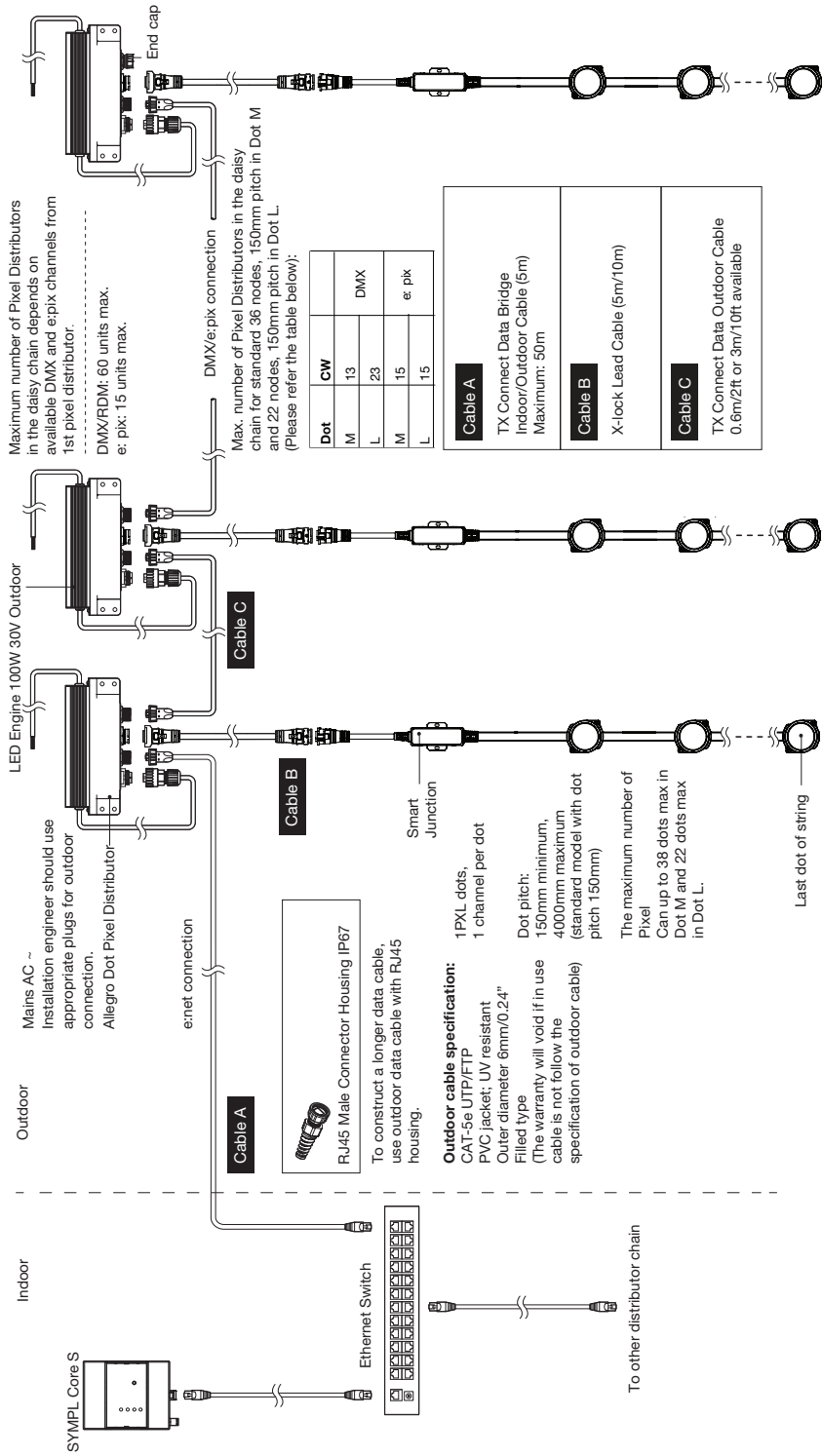

System Diagram—DMX / e:pix connection

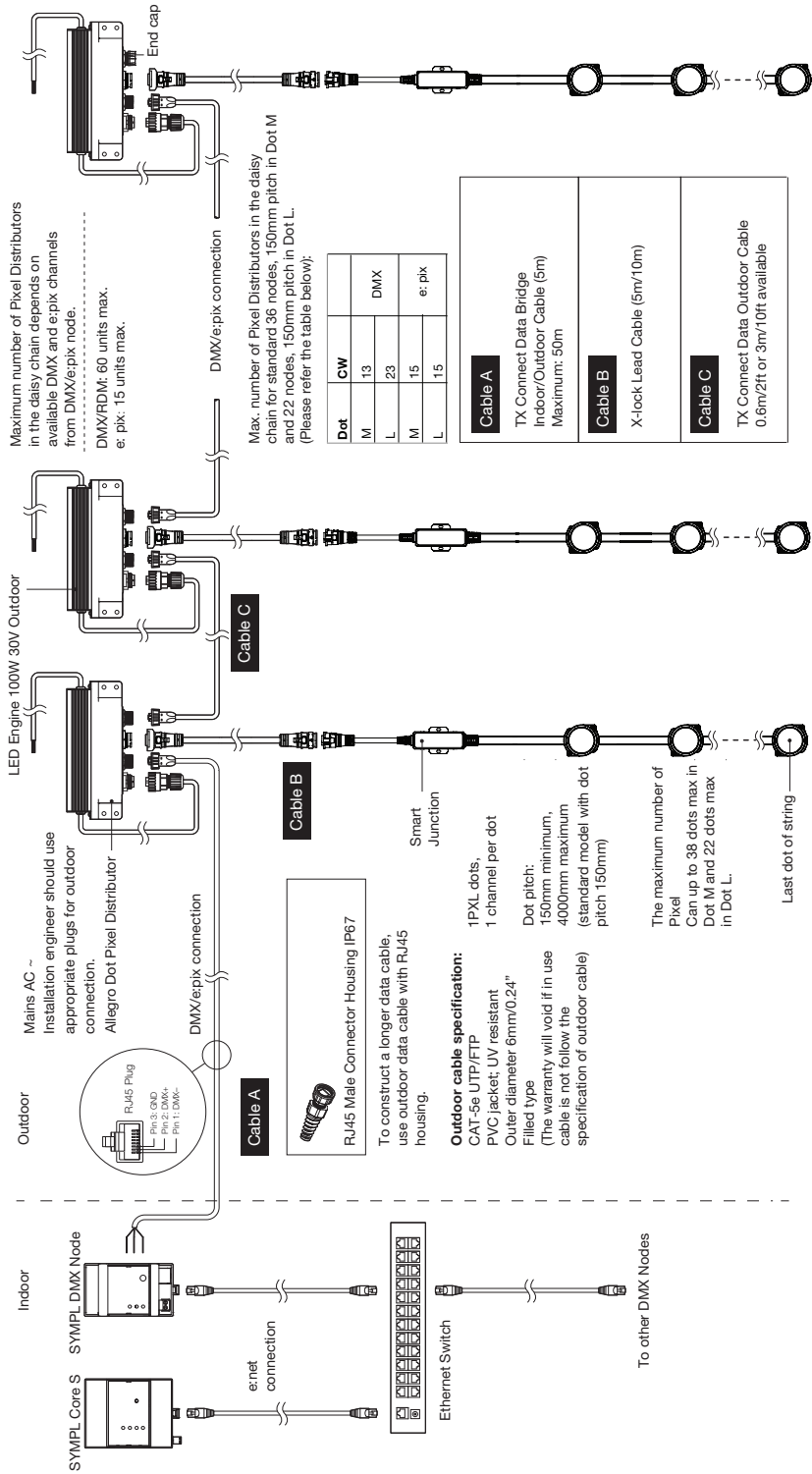



Allegro Dot M CW Allegro Dot L CW

Ordering

Fixtures

Model No.	Description	Item Code
DO.A2.5110020	AL DO M CR CW 36PPF 150P 0.5M WT	N/A
DO.A2.5210020	AL DO M DF CW 36PPF 150P 0.5M WT	N/A
DO.A2.5110030	AL DO M CR CW 36PPF 300P 0.5M WT	N/A
DO.A2.5210030	AL DO M DF CW 36PPF 300P 0.5M WT	N/A
DO.A3.5110020	AL DO L CR CW 22PPF 150P 0.5M WT	N/A
DO.A3.5210020	AL DO L DF CW 22PPF 150P 0.5M WT	N/A
DO.A3.5110030	AL DO L CR CW 22PPF 300P 0.5M WT	N/A
DO.A3.5210030	AL DO L DF CW 22PPF 300P 0.5M WT	N/A

Standard Accessories

Model No.	Description	Item Code
DO.AD.0001020	ALLEGRO DOT PXL DISTRIBUTOR	AM278810055
DO.AC.0100300	X-LOCK LEAD CABLE 5M 14AWG VS15 TX	AM061830055
DO.AC.0100400	X-LOCK LEAD CABLE 10M 14AWG VS10 TX	AM061850055

Optional Accessories

Model No.	Description	Item Code
N/A	AL DOT M/L FIELD CUT END CAP	AM355000055

E:cue Control

Model No.	Description	Item Code
N/A	SYMPL Core S	AB447060035
N/A	SYMPL DMX Node	AB444180035
N/A	SYMPL e:pix Node	AB443930035
EN.BP.0000100	Butler Pro DMX/RDM	AA628600035
EN.BP.0000200	Butler Pro e:pix	AA628610035
EN.BU.0000001	Butler S2	AB436200031
AC.BG.0000001	Butler S2 Garage (Optional)	AA611800031

TX Connect

Model No.	Description	Item Code
DE.AC.0000100	TX CONNECT Data Indoor/Outdoor Bridge Cable, 5m16.4ft	AA508850055
DE.IC.0060000	TX CONNECT Data Outdoor Cable, 0.6m/1.97ft	AA664580055
DE.IC.0300000	TX CONNECT Data Outdoor Cable, 3m/9.84ft	AA438810055
DE.AC.0100000	RJ45 Male Connector Housing IP67	AA556100155

TX Power

Model No.	Description	Item Code
N/A	LED ENG 100W 30V IP67 AL DO	AM019490055



©2019 TRAXON TECHNOLOGIES - AN OSRAM BUSINESS. ALL RIGHTS RESERVED. TRAXON™, TX CONNECT®, ARE TRADEMARKS OF TRAXON TECHNOLOGIES. U.S. PATENTS, E.U. PATENTS, JAPAN PATENTS, OTHER PATENTS PENDING. SPECIFICATIONS ARE SUBJECT TO CHANGE WITHOUT NOTICE.